

Internal forced convection to low-Prandtl-number gas mixtures

M. F. TAYLOR and K. E. BAUER

Aerospace and Mechanical Engineering Department, University of Arizona,
 Tucson, AZ 85721, U.S.A.

and

D. M. McELIGOT†

Gould, Inc., Middletown, RI 02840, U.S.A.

(Received 12 September 1984 and in final form 26 March 1987)

Abstract—Binary gas mixtures with Prandtl numbers in the range 0.18–0.7 were employed to test correlations proposed for turbulent, fully-established flow of a fluid with constant properties in a circular tube. The relations of Petukhov and Popov and of Kays fared best, while the popular Colburn analogy and the Dittus–Boelter correlation seriously overpredicted the Nusselt number at low Prandtl numbers. Effects of moderate property variation on overall average friction factors and local Nusselt numbers were also examined.

INTRODUCTION

THE COLBURN analogy [1]

$$St Pr^{2/3} = f/2 \quad (1a)$$

or, with the friction factor estimated as $f = 0.046 Re^{-0.2}$ [2]

$$Nu \approx 0.023 Re^{0.8} Pr^{1/3} \quad (1b)$$

and the Dittus–Boelter [3] correlation modified by McAdams [4]

$$Nu = 0.021 Re^{0.8} Pr^{0.4} \quad (2)$$

are probably the favorite design correlations for heat transfer to gases in fully-established conditions in circular tubes under the constant property idealization. These equations were developed empirically from data taken predominantly from liquid flows with the Prandtl number greater than unity and from a few experiments with common gases ($Pr \sim 0.7$).

In the last couple of decades a number of investigators have suggested alternate relations purported to cover a wider range of Prandtl number, particularly at the lower end of the range [5–9]. Table 1 lists the equations recommended and Fig. 1 demonstrates their trends in the range $0.1 < Pr < 1$, which includes gases and their mixtures. As one can see in the figure, all agree reasonably well near $Pr = 0.7$, with the possible exception of the Colburn analogy. However, as the Prandtl number is reduced they diverge significantly. Pierce [10] has shown that this divergence can lead to a 60% difference in the surface area or

volume of a heat exchanger for a gas turbine application!

Until recently this discrepancy has not been a problem. But in recent years mixtures of light and heavy molecular weight gases have been proposed for the working fluid for closed gas turbine cycles in order to optimize efficiency or power/weight ratio and some systems have been built [11–14]. These mixtures can have Prandtl numbers of 0.2 or lower. Gas pipeline operations also can involve mixtures with Prandtl numbers of the order of 1/3. The properties of ionized monatomic gases such as argon yield a range $0.1 \gtrsim Pr \gtrsim 0.7$ as well [15, 16].

Thus, the objective of the present work is to deter-

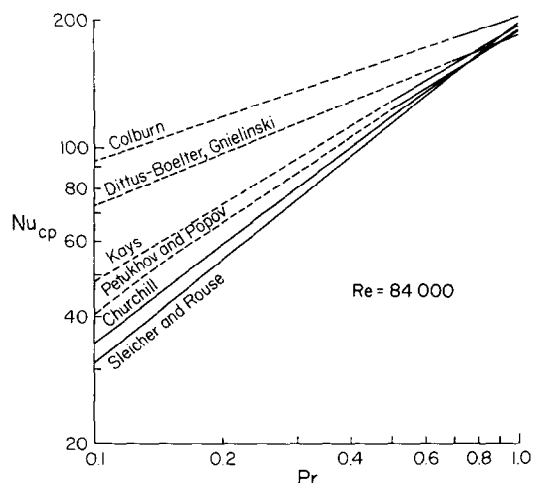

FIG. 1. Comparison of correlations recommended for turbulent, fully-established tube flow with constant properties.

† Professor Emeritus, University of Arizona.

Table 1. Equations proposed to predict turbulent, fully-established Nusselt number over a range of Prandtl number

Investigators	Correlation equations for constant properties	Suggested Pr range	Equation
Dittus and Boelter [3]	$Nu = 0.021 Re^{0.8} Pr^{0.4}$	0.7–1.0	2
Colburn [1]	$Nu = 0.023 Re^{0.8} Pr^{1/3}$	0.5–100	1b
Kays [5]	$Nu = 0.022 Re^{0.8} Pr^{0.6}$	0.5–1.0	3
Petukhov and Popov [6]	$Nu = \frac{(\xi/8) Re Pr}{K_1(\xi) + K_2(Pr) \sqrt{(\xi/8)(Pr^{2/3} - 1)}}$ $\xi = (1.82 \log Re - 1.64)^{-2}$ $K_1(\xi) = 1.34\xi \quad K_2(Pr) = 11.7 + 1.8Pr^{-1/3}$ $Nu = 5.0 + 0.015 Re^a Pr^b$	0.5–200	4
Sleicher and Rouse [7]	$a = 0.88 - 0.24/(4 + Pr)$ $b = 1/2 + 0.5 \exp\{-0.6Pr\}$	0.1–10 ⁵	5
Gnielinski [8]	$Nu = 0.0214(Re^{0.8} - 100)Pr^{0.4}(T_w/T_b)^{0.45}[1 + (D/L)^{2/3}]$	0.6–1.5	6
Churchill [9]	$Nu = 6.3 \frac{0.079 Re Pr \sqrt{f}}{[1 + Pr^{4/5}]^{5/6}}$ $\frac{1}{\sqrt{f}} = 2.21 \ln \left\{ \frac{Re}{7} \right\}$	all	7

lower than measurements of Saxena and Saxena [30] up to 1200°C (2190°F). DiPippo and Kestin did not report force constants for xenon, but Kestin *et al.* suggested force constants that predicted values of viscosity that are in very good agreement with the experimental data and predicted values of thermal conductivity that are about 4% lower than the reported measurements.

The properties of the helium–xenon mixtures are shown in Fig. 2. The solid curves were calculated using the force constants recommended by DiPippo and Kestin [27] for helium: $\sigma = 2.158 \text{ \AA}$ and $\epsilon/k = 86.2 \text{ K}$ and those recommended by Kestin *et al.* [29] for xenon: $\sigma = 3.858 \text{ \AA}$ and $\epsilon/k = 285.2 \text{ K}$. In this sequence of figures the dashed curves are based on the force constants of Hirschfelder *et al.* [22].

The viscosity of the mixtures varies considerably with the molar mass (molecular weight) of the mixture. At 277°C (530°F) the maximum viscosity of the mixture is 41% higher than that of helium and 5% higher than xenon. Viscosity predicted using constants from DiPippo and Kestin [27] and Kestin *et al.* [29] or from Hirschfelder *et al.* [22] agree to within 3% of the data of Trautz and Heberling [31] and Thornton [32]. As with pure gases the viscosity increases with temperature.

The mixture thermal conductivity decreases by a factor of 23 as the molar mass increases from pure helium to pure xenon over the range of mixture temperature in this investigation, and mixture conductivity also increases with temperature. Agreement with the data of Thornton [32], Gandhi and Saxena

[33] and Mason and von Ubish [34] is good for temperatures ranging from 18 to 90°C (65 to 194°F). The only data available at higher temperatures appear to be those of Mason and von Ubish at 520°C (968°F) and these are almost 10% higher than the predictions; however, in a critical review Gandhi and Saxena [33] have observed that the measurements of Mason and von Ubish appear to be systematically higher than others they reviewed.

As a consequence of the variation of thermal conductivity and specific heat vs molar mass or concentration, the Prandtl number decreases to a minimum of about 0.21 at $\tilde{M} \approx 50$ from about 0.667 for the pure gases. It is about 0.23 at the molar mass of air.

It is interesting to note that even though the force constants of Hirschfelder *et al.* [22] did not adequately predict thermal conductivity and viscosity for pure helium and xenon, their predictions for the mixtures did not differ greatly from the ones used in this investigation.

The hydrogen–xenon mixtures were also assumed to be ideal gases, making the compressibility equal to unity. This assumption is also reasonable for the range of pressures (750–800 kPa or 7.4–7.9 atm) and temperatures (290–830 K or 62–1040°F) used in this experiment. The specific heat of this mixture was calculated by the relation

$$c_{p,\text{mixture}} = (\text{mass fraction}_{\text{H}_2})c_{p,\text{H}_2} + (\text{mass fraction}_{\text{Xe}})c_{p,\text{Xe}}$$

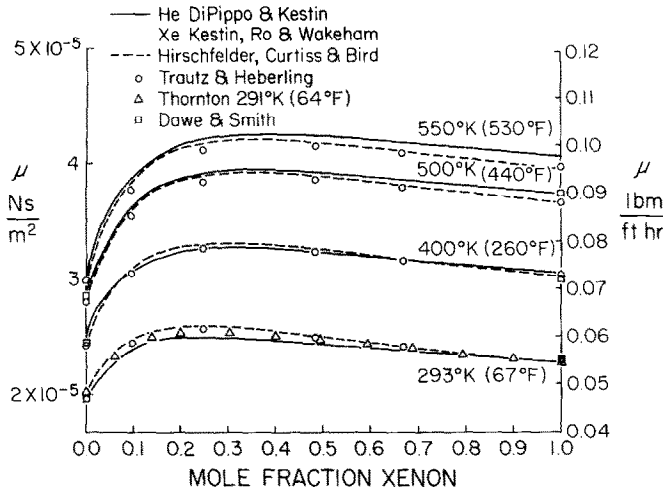

FIG. 2(a). Transport properties of He-Xe mixtures (pressure = 1 atm).

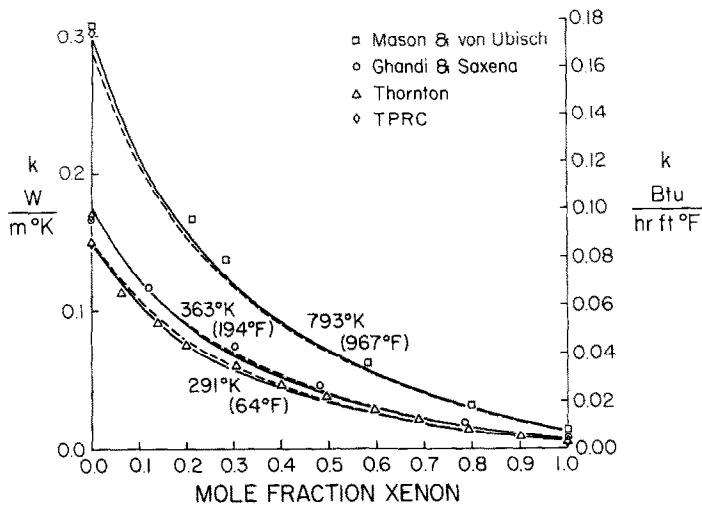

FIG. 2(b). Transport properties of He-Xe mixtures (pressure = 1 atm).

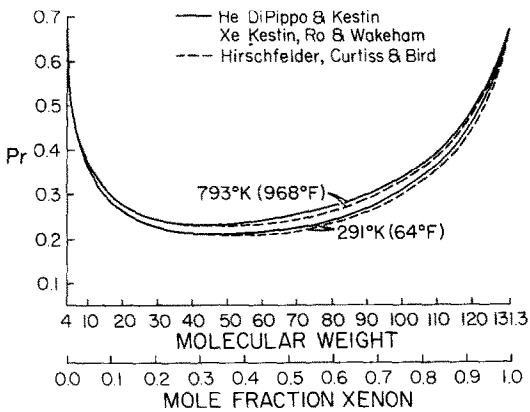

FIG. 2(c). Transport properties of He-Xe mixtures (pressure = 1 atm).

The enthalpy and speed of sound were calculated in the same manner as with the helium-xenon mixture. The trends of the hydrogen-xenon mixture properties are comparable to those of helium-xenon and

helium-argon [35] mixtures; details are plotted in a report by the present authors [36]. Viscosity was calculated using the viscosities of hydrogen and xenon and the method recommended by Hirschfelder *et al.* [22] for calculating mixtures of monatomic gases. Hydrogen is, of course, polyatomic and predicting its properties is more complex than predicting those of monatomic gases. Thermal conductivity was calculated using the method of Lindsay and Bromley [37].

The only measurements of viscosity of hydrogen-xenon mixtures found in the literature were those of Trautz and Heberling [31] which are in good agreement with these predictions, especially at the mole fraction of xenon (0.21) in the mixture used in the present investigation. The viscosity of the mixture increases with temperature and the increase in viscosity from pure hydrogen to pure xenon is threefold.

The mixture thermal conductivity decreases by a factor of 30 as the molecular weight increases from pure hydrogen to pure xenon over the temperature

range of this investigation. Only two investigations of thermal conductivity of hydrogen-xenon mixtures were found. Barua [38] measured conductivities for mixtures of eight volume-percentages of xenon from 0 to 100% at temperatures of 30°C (85°F) and 45°C (111°F). Saxena and Tondon [39] measured conductivities for five mole fractions of xenon from 0 to 1.0 at 40, 65 and 93°C (104, 149 and 199°F). The measurements of the two investigations are in good agreement with each other, particularly near the mixture concentration ($x_{Xe} = 0.21$) used in this investigation but are as much as 15% higher than predicted values at 93°C (199°F).

For the present concentration, the experimental values of thermal conductivity were extrapolated to the maximum mixture temperature used and it was found that extrapolated conductivity was 20% higher than the predicted value. A method recommended by Kestin [40], but not with complete confidence, is described by Clifford *et al.* [41]. The thermal conductivities calculated by this method are closer to the extrapolated experimental values than those predicted by the method of Lindsay and Bromley, but are still 15% low at 283°C (541°F). As a consequence of this difference in estimates of thermal conductivity, data reduction for the H₂/Xe heat transfer measurements in this investigation was performed twice, once using the lower predicted values and once using the values obtained by extrapolating the experimental values. The normalized Nusselt number (Nu/Nu_{DB}) was found to be 6–10% higher when the thermal conductivity determined by the method of Clifford *et al.* [41] was used rather than the extrapolated experimental value.

As a result of the variations of the calculated thermal conductivity, viscosity and specific heat vs the molar mass, the calculated Prandtl number decreases to a minimum of about 0.18 at $\tilde{M} = 47$ from 0.707 for hydrogen and 0.667 for xenon near room temperature. It is about 0.20 at $\tilde{M} = 29$ which is the molar mass of both air and the hydrogen-xenon mixture used in this investigation. When based on the experimental thermal conductivity a value of 0.18 is predicted for this situation.

For the first objective—constant properties correlations—it is the room temperature properties that are important as a consequence of the technique which was used in deducing the Nusselt number for constant property conditions. The calculated and experimental values of properties agree reasonably well near room temperature. Thus, the discrepancy discussed above is only important relative to the secondary objective—effect of temperature-dependent properties or heating rate—for one mixture employed.

THE EXPERIMENT

Apparatus

The experimental apparatus, arrangement and procedure were similar to those used by Park *et al.* [42].

In the present investigation the loop was a closed circuit, as shown in Fig. 3, due to the extremely high cost of the xenon gas. A single-acting 'Gas Booster Pump' from Haskel Manufacturing Company circulated the gas mixtures through two pressure regulators, a plenum, a cooler which removed the heat of compression, a tubular flowmeter, the instrumented test section, another cooler to remove the energy added in the heated test section, a UGC densitometer, another plenum, a control valve and then back into the pump. The two pressure regulators and plenum were installed to remove the pressure fluctuations in the flow created by the pump. Two pressure transducers were used to measure the pressure fluctuations; a Model SCD 147 from Data Instruments, Inc. was located just beyond the first cooler and a Kulite Model XT-140-100G subminiature pressure transducer was mounted flush with the inside of the tube immediately beyond the elbow at the entry of the test section to measure the pressure fluctuations of the flow entering the test section.

The vertical test section was a circular tube of Inconel 600 with an inside diameter of 5.87 mm (0.231 in.) and a wall thickness of 0.28 mm (0.011 in.). It consisted of a heated section 60 diameters in length preceded by an unheated section of 56 diameters which insured that the flow approached a fully developed velocity profile prior to heating.

The test section itself served directly as an electrical resistance heater. Alternating current from a line voltage stabilizer was supplied via variable transformers to the test section through thin stainless steel electrodes brazed to the tube. The current was measured using a Weston current transformer and a Weston Model 370 ammeter. A high impedance Fluke differential voltmeter measured the voltage across the test section to serve as a check on power measurements. Three pressure taps, with holes of about 0.30 mm (0.012 in.), were used. One was located five diameters below the lower electrode and the other two were 50 and 54 diameters above it, near the upper electrode. The static pressure at the test section inlet was measured with a Heise bourdon tube gauge and the pressure drop between taps was measured with an MKS Baratron Type 77 Pressure Meter and Head. The fluctuating signals from the Kulite pressure transducer were recorded on a Hewlett-Packard x-y recorder.

Twenty-one premium grade chromel-alumel thermocouples, 0.013 cm (0.005 in.) in diameter were spot welded to the heated section of the tube using the parallel junction technique suggested by Moen [43]. Thermal conduction error was calculated from the heat loss calibration data and a relation developed by Hess [44]; the thermocouple conductance was estimated from the emissivity of the bare wire and a natural convection correlation for small Rayleigh numbers [45]. The correction was of the order of 1% of the difference between the tube temperature and the environmental temperature; at $Re \sim 3 \times 10^4$ this

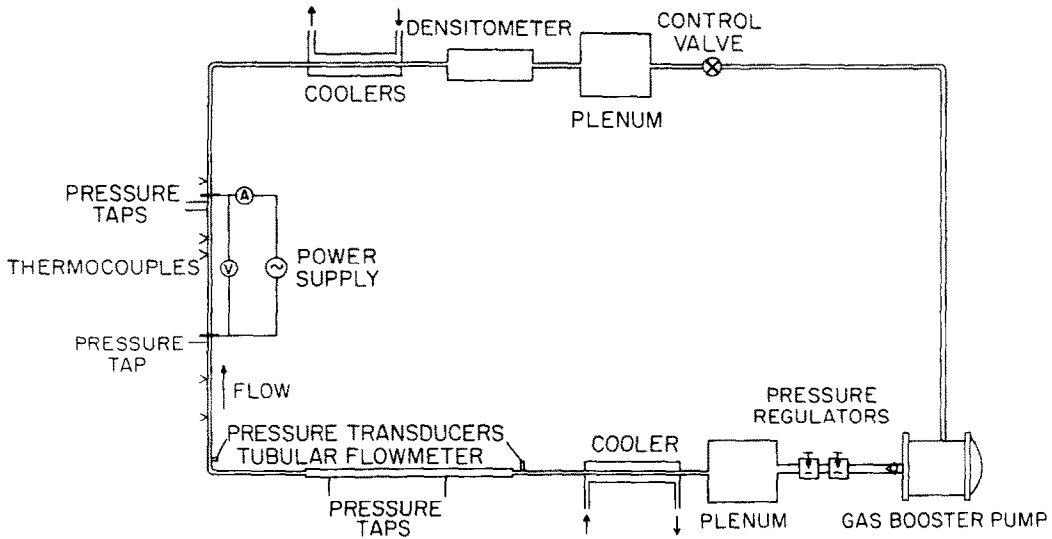

Fig. 3. Schematic diagram of experimental apparatus.

correction was equivalent to 1.5–2% in the Nusselt number.

Procedures and preliminary measurements

The test section was a bare tube surrounded by a draft shield so the heat loss was by radiation and natural convection. The heat loss was calibrated as a function of axial position and temperature from measurements with a vacuum on the inside of the test section. The uncertainty of the heat loss measurements was estimated to be about 1%. The heat loss data were represented by cubic equations that deviated no more than 3% except at very low test section temperatures (121°C, 250°F) where the deviation might be as much as 10%. However, for the flow runs reported the heat loss was usually less than 10% of the power dissipated; for these runs the effect of the deviation would be less than 1% of the power dissipated. A few runs with $Re_t < 36\,000$ and $T_w > 650^\circ\text{C}$ (1200°F) had heat losses locally exceeding 20% of the energy generated. The electrical resistance of the test section was also measured as a function of temperature during the heat loss runs; the estimated uncertainty was also about 1%.

The closed loop was pressurized with gases and gas mixtures from high pressure cylinders. A cylinder of a helium–xenon gas mixture with a molar mass of 83.8 was obtained from the NASA–Lewis Research Center. Helium–xenon mixtures of lesser molar mass were obtained in the loop by adding helium to the existing gas mixture. On the other hand, the hydrogen–xenon mixture was obtained by mixing high purity hydrogen directly with high purity xenon. The partial pressures of the gases in a mixture were used to calculate the quantity of helium needed to reduce the molar mass of the helium–xenon mixture and also to determine the amounts of hydrogen and xenon

needed to obtain the particular mixture for a given run.

The UGC gas densitometer was calibrated with air, argon, helium and the helium–xenon gas mixture ($\bar{M} = 83.8$) over the pressure range of this investigation. It was used to verify the results of mixing the gases to predetermined concentrations *in situ* and also for checking the concentrations after a series of runs. This was done by comparing the measured density with the density calculated using the measured temperature and pressure and the perfect gas law. The measured and calculated densities usually agreed within 1% and the mixture molar mass did not change measurably during the runs.

Mass flow rate was determined with the tubular flowmeter, which was itself calibrated over the range of interest using several positive displacement flowmeters in parallel. The mass flow rate could be determined within an uncertainty of 1.5% or better.

Park *et al.* [42] reported the results of an experiment on the effects of pulsating flow on heat transfer to air; they employed the same apparatus modified to an open loop configuration so that the mass flow rate could be measured directly with positive displacement flowmeters at the exit. The static pressure fluctuations were as large as could be attained with the gas booster pump in this system (9–35%). Frequency ranged from 2.1 to 3.6 Hz, q^+ from 0 to 0.0034 and Reynolds numbers from 18000 to 102000. For the range of conditions in the present investigation the effect of pressure fluctuations as large as 26–35% had less than a 2% effect on the Nusselt number [42]. In the experiments of the present paper the pressure fluctuations were never more than 0.6% (usually less than 0.2%) and had a frequency no greater than 2.0 Hz. Thus, the magnitude of any effect of pressure fluctuations in the present gas mixture experiments is believed to be

negligible. Results from runs made with pulsating air at the present levels in the closed loop compared closely with those from similar runs conducted with the loop open and no pressure fluctuations.

The procedure for the experimental runs was to introduce the proper amount of gases into the closed loop and then to circulate the mixture until the density of the gas reached steady state as measured by the densitometer. The mass flow rate was set to give the required Reynolds number, and then the electrical power to the test section was adjusted to give a series of maximum wall temperatures of approximately 120°C (250°F), 260°C (500°F), 400°C (750°F), 540°C (1000°F) and 680°C (1250°F). After covering the range of wall temperatures desired, the mass flow rate could be changed to give the next required Reynolds number. Once the range of Reynolds number was covered, the power was shut down and the gas flow stopped. At this time the density was again measured to determine whether the molar mass had changed due to preferential leakage of the hydrogen or helium. No change in molar mass could be detected at any time during the experiments.

During each run the wall temperatures along the heated and unheated test section were recorded along the inlet static pressure and the pressure difference across both the tubular flowmeter and the heated test section. The current through the test section and the voltage drop were recorded. The bulk temperature of the gas entering the tubular flowmeter was measured and the bulk temperature of the gas at the thermal entrance was deduced from this measured temperature and the wall temperatures of the unheated section just downstream of the start of heating.

The data were reduced to give local heat transfer and fluid flow parameters. As described later in the Results, for each gas mixture and Reynolds number, the ratio of measured Nusselt number to the Nusselt number predicted by Dittus and Boelter [3] was plotted vs the wall-to-bulk temperature ratio and was then extrapolated to $T_w/T_b = 0$ in order to deduce the local value of the Nusselt number corresponding to constant property conditions. This constant property Nusselt number was compared to the predicted values suggested by the several investigators mentioned earlier. The heat transfer and friction data with property variation were also reduced and compared with existing correlations.

Experimental uncertainties

The experimental uncertainties were estimated by the method of Kline and McClintock [46]. Typical uncertainties for the Nusselt number were about 8% at $x/D \simeq 1.3$ decreasing to 5% at $x/D > 24$ for low heating rates, and about 1.4% at $x/D \simeq 1.3$ increasing to 4% at $x/D > 24$ for the higher heating rates. These estimates are in good agreement with the estimates made by Serksnis [18] for H_2 - CO_2 experiments and by Pickett [17] for He-Ar experiments, both in open loop configurations. For the low heating rates, the

dominant uncertainties are due to the inlet bulk gas temperature and the wall temperatures. For higher heating rates, the uncertainty increases with x/D because the uncertainties in tube wall temperature and, therefore, temperature difference increase significantly with temperature level, while the contributions of uncertainties in mass flow rate, electrical power and inlet gas temperature remain small. Further details of the typical uncertainties for measurements with air, He-Xe ($\bar{M} \sim 40$) and H_2 -Xe ($\bar{M} \sim 29$) as the working fluid are tabulated by Taylor *et al.* [36].

The estimates of the experimental uncertainties do not include the contributions of the uncertainties in the properties themselves. If one writes the proposed correlation of Kays [5] as

$$Nu = C Re^{0.8} Pr^{0.4}$$

and considers the experimental problem as one of determining the constant C , then it can be seen that the direct effects of the properties appear in terms of fractional powers

$$C \sim \frac{h}{\bar{m}^{0.8} D^{0.2}} \frac{\mu^{0.2}}{k^{0.4} c_p^{0.6}}$$

Thus, a 20% uncertainty in thermal conductivity would lead to about 8% uncertainty in C . While not negligible, this value corresponds to an upper limit occurring in the highest temperature measurements with the H_2 -Xe mixture. The resulting uncertainty in C would not be large enough to modify the major conclusions of the study.

Reproducibility

The reproducibility of the measurement technique was checked in two ways. Air data in steady flow had been obtained previously in two other test sections by Pickett [17] and Serksnis [18]. It was found that each had a series of runs at Re_i near 80 000 and various heating rates so these were compared to present measurements at the same conditions. For the three sets of data which spanned a five year period, it was found that in the downstream region the normalized Nusselt number, $Nu/(0.021 Re^{0.8} Pr^{0.4})$, agreed to within 3% at low heating rates ($T_w/T_b \sim 1.2$) and within 2% at higher heating rates ($1.4 < T_w/T_b < 1.8$).

Secondly, the reproducibility of the present measurements was tested at the end of the experiments by duplicating one of the first runs with $Re_i \simeq 60 000$, $q^+ = 0.0014$ (maximum $T_w/T_b \sim 1.5$) and steady conditions. The mass flow rate could be reproduced to better than 0.2%, the gage pressure at the test section inlet to within less than 0.1% and the electrical current to within the accuracy of the ammeter ($\sim 0.25\%$). The resulting values of $(T_w - T_{b,in})_{max}$ differed by 2.1%, leading to agreement of the fully developed Nusselt numbers within less than 3% again.

Table 2. Range of variables in the present investigation

Gas	Air	He-Xe	He-Xe	He-Xe	He-Xe	H ₂ -Xe
Molar mass (molecular weight)	28.97	83.8	40	28.3	14.5	29
Inlet bulk Prandtl number	0.717	0.251	0.214	0.231	0.301	0.181
Experimental runs	16	10	10	4	5	4
Inlet bulk Reynolds number	33 900–85 800	32 600–87 400	34 300–61 800	48 400–55 400	34 000–40 900	71 100–73 900
Exit bulk Reynolds number	21 600–77 900	16 500–74 300	19 200–51 800	26 200–43 000	19 500–36 700	43 400–66 700
Maximum T_w/T_b	2.38	2.22	1.99	2.06	2.04	1.78
Maximum T_w (K)	974	962	941	982	972	832
Maximum q^+	0.0044	0.0069	0.0053	0.0051	0.0047	0.0034
Maximum Gr/Re_1^2	1.40×10^{-2}	1.44×10^{-2}	9.34×10^{-3}	6.67×10^{-3}	3.05×10^{-3}	3.29×10^{-3}
Maximum Mach number	0.109	0.123	0.079	0.090	0.075	0.103
x/D for local bulk Nusselt numbers	2.2–52.4	2.2–52.4	2.2–52.4	2.2–52.4	2.2–52.4	2.2–52.4

EXPERIMENTAL RESULTS

The ranges of the present data are presented in Table 2 and tabulations of these data are provided in the report by Taylor *et al.* [36]. Data for He–Ar mixtures are tabulated in the report by Pickett [17] and for H₂–CO₂ mixtures by Serksnis [18].

Heat transfer with constant properties

To compare experimental data with constant property correlations the measurements were extrapolated to the constant property idealization by an approach like that of Malina and Sparrow [47]. For this method, a series of experimental runs was taken with the same inlet Reynolds number and gas composition but with successively higher heating rates. At each thermocouple location the normalized value of the measured Nusselt number, $Nu(x)/Nu_{DB}(x)$, was plotted vs the local ratio of wall and bulk temperatures, T_w/T_b , as demonstrated in Fig. 4. Brackets represent the estimated experimental uncertainties. An extrapolation to $T_w/T_b = 1$ yielded the local Nusselt number corresponding to constant property conditions, $Nu_{cp}(x)$. For the H₂–Xe mixtures the measured properties were employed rather than the calculated versions.

The variations of Nu_{cp}/Nu_{DB} with T_w/T_b for several thermocouple locations are shown in Fig. 4 for three binary gas mixtures. The trends are the same for each mixture. In the thermal entry at low x/D the variation with temperature ratio is slight and the Nusselt number is higher than further downstream. As with constant property predictions, e.g. Kays [5], the local Nusselt numbers decrease with increasing axial distance until they begin to fall on an asymptotic locus. For these data this quasi-developed condition [48] appears to be approached at about 25 diameters. The extrapolated value ($T_w/T_b = 1$) of these asymptotic curves then provides the ‘experimental’ fully-established Nusselt number for constant properties—the situation for which the empirical correlations of Table 1 are meant to hold.

For fully-established conditions with air as the fluid, the ratio Nu_{cp}/Nu_{DB} was about 0.94 for Reynolds numbers from about 34 000 to 85 000 without any

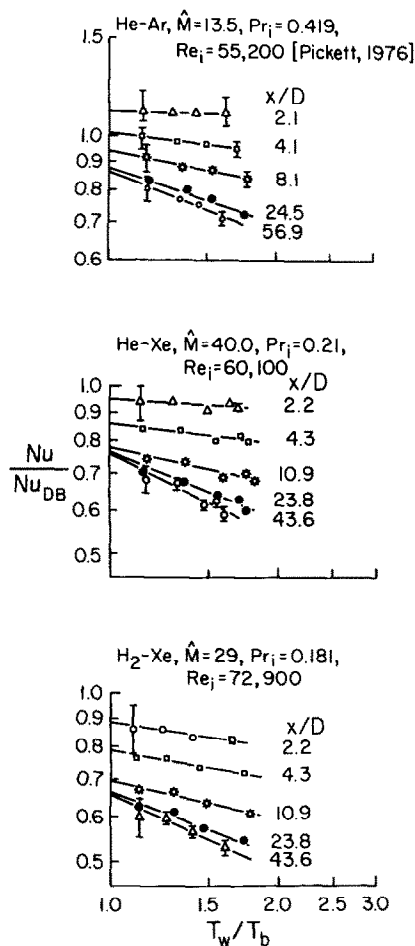

Fig. 4. Technique for determining Nusselt numbers at constant property conditions.

apparent dependence on Reynolds number. For the binary mixtures, it can readily be seen that the fully-established values of Nu_{cp}/Nu_{DB} decrease from 0.94 for a Prandtl number of 0.72, to 0.86 at $Pr = 0.42$, 0.76 at $Pr = 0.21$ and 0.66 at the lowest Prandtl number. This reduction in the normalized value corresponds to the trend predicted by an analysis by Pickett *et al.* [35].

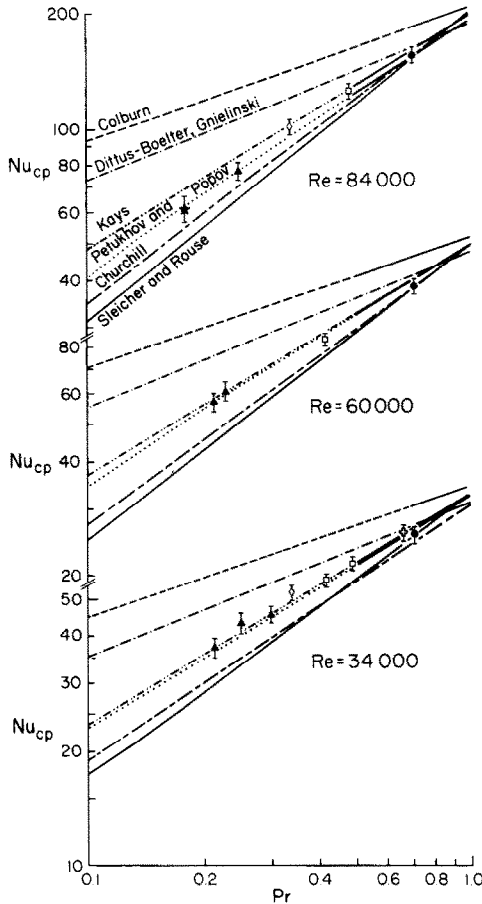

FIG. 5. Comparison between measurements and recommended correlations. Fully-established tube flow.

The constant property Nusselt numbers for Prandtl numbers from 0.18 to 0.72 for three Reynolds numbers are compared to the correlations of Table 1 in Fig. 5. For these plots a correction based on $Nu \sim Re^{0.8}$ was applied to adjust the data slightly to common values of the Reynolds number. Experimental uncertainties, denoted by brackets, were estimated by extrapolating the experimental uncertainties from plots like Fig. 4. The solid symbols denote data from the present investigation. The air data from Pickett [17], Serksnis [18] and the present investigation agreed to within less than 3% and are represented by a single solid symbol.

As the Reynolds number increases, the deviation between the predictions of the various correlations becomes greater. Since most of the correlations agree with one another for common gases ($Pr \sim 0.7$) at low Reynolds numbers, the data at low Prandtl numbers and high Reynolds numbers are needed to discriminate between them. Of the correlations tested, those of Kays [5] and Petukhov [6] agreed best. At Reynolds numbers of 34 000 and 60 000 there is little difference between the values predicted by Kays [5] and by Petukhov [6] and for Prandtl numbers from about 0.2 to 0.72 both are in reasonably good agreement

with our data. However, for a Reynolds number of 84 000 the difference between these two correlations widens and the relation of Petukhov agrees more closely with experiments at the lower end of the Prandtl number range.

Overall, the relation from Petukhov appears best for the range of the present data. At low Prandtl numbers the extrapolations of the Colburn analogy and the Dittus-Boelter equation would overpredict the heat transfer parameters seriously.

Heating with property variation

If power densities are to be increased or the weight of systems such as the closed cycle gas turbine reduced, moderately high heating rates must be employed. Then the temperature dependence of the fluid transport properties will cause significant variation in properties appearing in the correlation equations for both heat transfer and friction coefficients. Results and correlations based on the constant properties idealization can become invalid.

As a consequence of the technique employed to deduce constant property results (Fig. 4), the present data also provide insight into the effects of moderate property variation on heat transfer and wall friction for these mixtures. In this section correlations accounting for property variations are examined.

Since pressure taps were installed only near the entrance and exit of the test section, local friction factors could not be determined in this investigation. Overall average friction factors with heat addition were compared with a modified Drew *et al.* correlation [49] as proposed by Taylor [50] for $0.62 < Pr < 0.81$

$$f_{av} = (0.0014 + 0.125Re_w^{-0.32})(T_{w,av}/T_{b,av})^{-0.5} \quad (10)$$

for the data of a wide variety of experiments with common gases. Most previous measurements agreed with relation (10) within 10%.

For evaluation of equation (10) integrated averages of both the local wall and local bulk gas temperature were used along with the average pressure to determine average density and viscosity. The integration was evaluated from the start of heating at $x = 0$ to $x/D = 54.5$, the position of the third pressure tap allowing for thermal expansion. The overall friction factor was determined from the frictional pressure drop

$$\Delta p_{fr} = p_1 - p_2 - \frac{G^2 R}{g_c} \left[\frac{T_{b_2}}{p_2} - \frac{T_{b_1}}{p_1} \right] \quad (11)$$

and the modified wall Reynolds number was defined as

$$Re_w = (GD/\mu_w)(T_{b,av}/T_{w,av}). \quad (12)$$

In the present study Taylor's correlation (10) predicted most of the data to within 5%. These measurements are presented in Fig. 6. The few data deviating more than 5% below the correlation were binary mixture runs with maximum wall temperatures in excess

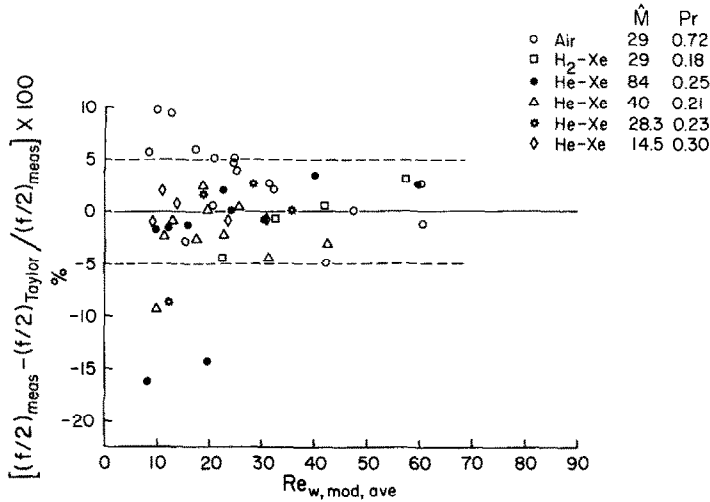

FIG. 6. Comparison of average friction factors to Taylor [50] correlation for variable gas properties.

of 665°C (1230°F), $T_w/T_b > 1.8$ and with modified wall Reynolds numbers in the low range between 8000 and 20 000, where experimental uncertainties are greatest. The data deviating more than 5% above were all air runs with modified wall Reynolds numbers between 8500 and 17 500. There appeared to be no variation with Prandtl number.

The effects of heating rate or transport property variation on *local Nusselt numbers* have been indicated earlier in Fig. 4. In the quasi-developed region [48] for $x/D > 25$ the trends are the same for the three gas mixtures shown. As the difference between wall temperature and the bulk temperature increases (and the differences between wall and bulk properties increase), the ratio $Nu(x)/Nu_{DB}(x)$ decreases showing an increase in thermal resistance. The rate of decrease with T_w/T_b appears to increase slightly as the Prandtl number is decreased but a simple relation remains adequate for a design correlation.

Experimental values of the local Nusselt numbers were compared to Nusselt numbers predicted by modified forms of the prediction equations recommended by Pickett [17]

$$Nu_b = 0.021 Re_b^{0.8} Pr_b^b [(T_w/T_b)^{-0.4} + 0.85D/x] \quad (13)$$

and by Taylor [51]

$$Nu_b = 0.023 Re_b^{0.8} Pr_b^b (T_w/T_b)^{-a} \quad (14)$$

where

$$a = [0.57 - 1.59/(x/D)].$$

For the present comparisons a value of 0.65 was finally taken for b , the exponent of the Prandtl number, in both of these equations. This exponent corresponds approximately to the correlation of Petukhov in this regime.

Figure 7 shows the ratios of the measured Nusselt number to the Nusselt number predicted from equa-

tions (13) and (14) with $b = 0.65$ for two heating rates each with air, He-Xe ($\hat{M} = 14.5$, $Pr = 0.30$) and H₂-Xe ($\hat{M} = 29$, $Pr = 0.18$). For the H₂-Xe mixture the measured properties or extrapolated measured properties were again used rather than the predicted values. The data shown here are typical of all data measured in this investigation. Both correlation equations appear to predict downstream Nusselt numbers with acceptable accuracy for all three Prandtl numbers. Both equations predict entrance effects better for the low heating rate than for the higher rate and are in close agreement with each other even though the methods of handling entrance effects in the two correlations are different. Obviously, a better treatment of entrance effects is needed, but in many applications the wall temperatures are lowest in the thermal entrance so it is not necessarily critical. For all axial distances greater than 2.2 diameters, examination of air data with Reynolds numbers of about 34 000, 65 000 and 85 000 showed less than 3% variation of $Nu(x)/Nu_b(x)$ with Reynolds number for a particular heating rate. The same observation held true for the gas mixtures when data for two Reynolds numbers were available for comparison at the same mixture concentration.

The Taylor correlation and variable-property versions of the Dittus-Boelter relation [52] utilize $b = 0.4$ for the Prandtl number dependence. For all Prandtl numbers, increasing the exponent of the Prandtl number to 0.65 yielded considerable improvement in the predictions using equations (13) and (14). The value of $Pr^{0.65}/Pr^{0.4}$ is 0.65 for $Pr = 0.181$, 0.74 for $Pr = 0.30$ and 0.92 for air; so it is clear that an experimental determination of the best exponent for Prandtl number is far more difficult using common gases than with these lower Prandtl number mixtures for which the sensitivity of the Nusselt number to the exponent on the Prandtl number is much greater. Further discrimination may be possible by mixing helium or hydrogen with gases of higher molar mass

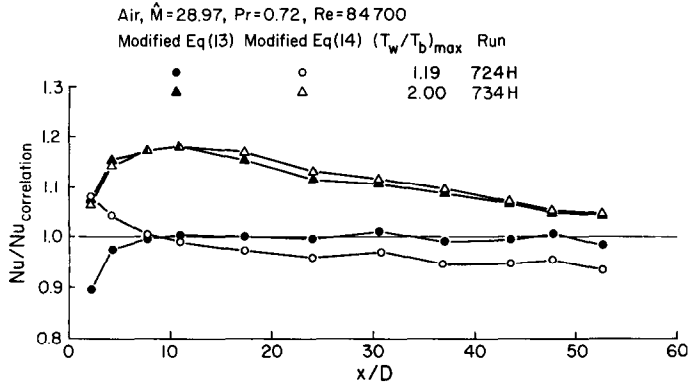

FIG. 7(a). Comparison to correlations for heat transfer with gas property variation (air).

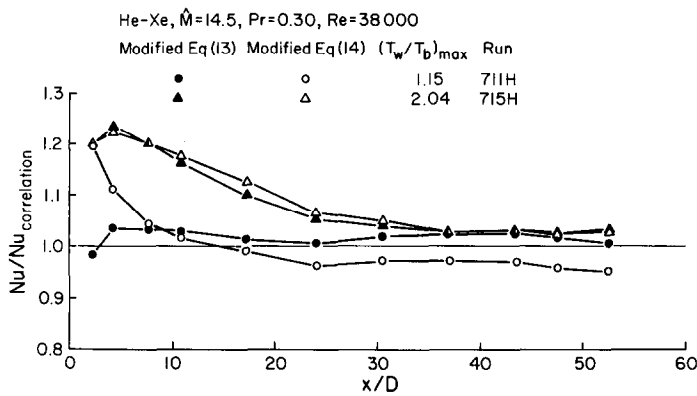
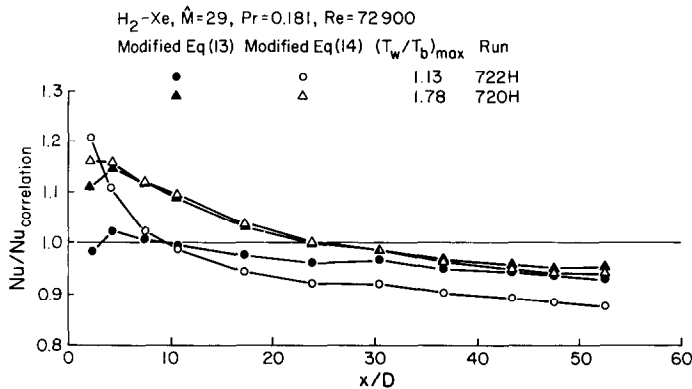

FIG. 7(b). Comparison to correlations for heat transfer with gas property variation (He-Xe mixture).

FIG. 7(c). Comparison to correlations for heat transfer with gas property variation (H_2 -Xe mixture).

to obtain lower Prandtl numbers, thereby approaching the range of liquid metals.

CONCLUSIONS

From experiments with heated flow of He-Xe and H_2 -Xe mixtures with Prandtl numbers in the range 0.18–0.30 and the conditions of Table 2, the following major conclusions may be drawn. The Colburn analogy and the Dittus-Boelter correlation, based on measurements for $Pr \lesssim 0.7$, seriously overpredict Nusselt numbers for fully-established conditions with constant properties in this range. Of the correlations

examined, those of Petukhov [6] and of Kays [5] best represent the data for constant property Nusselt numbers over the range of $0.18 \lesssim Pr \lesssim 0.72$ with fully-established conditions.

For modified wall Reynolds numbers greater than 20 000, the overall average friction coefficients for flow with moderate property variation were predicted within $\pm 5\%$ by correlation (10) proposed by Taylor [50]. For local Nusselt numbers in flow with moderate property variation, correlation (14), with the exponent of the Prandtl number increased to 0.65, is recommended for axial distances greater than 20 diameters.

Acknowledgements—We are grateful to the support of Mr M. K. Ellingsworth of the Office of Naval Research which made this work possible under Contract N00014-75-C-0694. Thanks are due also to the late Dr William Harrach of AiResearch Manufacturing Company, Arizona, who originally suggested the topic, and to the Hydrodynamics Research Department of the Ocean Systems Division, Gould, Inc., for assistance in preparation of the manuscript. By acceptance of this article for publication, the publisher recognizes the U.S. Government's (license) rights in any copyright and the Government and its authorized representatives have unrestricted right to reproduce in whole or in part said article under any copyright secured by the publisher.

REFERENCES

1. A. P. Colburn, A method of correlating forced convection heat transfer data and a comparison with liquid friction, *Trans. AICIE* **29**, 174–210 (1933).
2. A. J. Chapman, *Heat Transfer*, 4th Edn. Macmillan, New York (1984).
3. F. W. Dittus and L. M. K. Boelter, Heat transfer in automobile radiators of the tubular type, *Univ. Calif. Publs Engng* **2**, 443–461 (1930).
4. W. H. McAdams, *Heat Transmission*. McGraw-Hill, New York (1954).
5. W. M. Kays, *Convective Heat and Mass Transfer*. McGraw-Hill, New York (1966).
6. B. S. Petukhov, Heat transfer and friction in turbulent pipe flow with variable physical properties, *Adv. Heat Transfer* **6**, 503–564 (1970).
7. C. A. Sleicher and M. W. Rouse, A convenient correlation for heat transfer to constant and variable property fluids in turbulent pipe flow, *Int. J. Heat Mass Transfer* **18**, 677–683 (1975).
8. V. Gnielinski, Neue Gleichungen für den Wärme- und den Stoffübergang in turbulent durchströmten Rohren und Kanälen, *Sonderdr. Forsch. Ingenieurweser* **1**, 8–16 (1975). Also *Int. Chem. Engr* **16**, 359–368 (1975).
9. S. W. Churchill, Comprehensive correlating equations for heat, mass and momentum transfer in fully developed flow in smooth tubes, *Ind. Engng Chem. Fundam.* **16**(1), 109–116 (1977).
10. B. L. Pierce, The influence of recent heat transfer data on gas mixtures (He–Ar, H₂–CO₂) on closed cycle gas turbines, *Trans. Am. Soc. Mech. Engrs*, Series A, *J. Engng Pwr* **103**, 114–117 (1981).
11. M. R. Vanco, Analytical comparison of relative heat transfer coefficient and pressure drop of inert gases and their binary mixtures, NASA TN-D-2677 (1964).
12. T. W. Phillips, Closed cycle gas turbine as a proposed undersea power source, *J. Hydronautics* **3**, 184–190 (1969).
13. K. Bammert, G. Rurik and H. Griepentrog, Highlights and future developments of closed cycle gas turbines, ASME paper 74-GT-7 (1974).
14. H. B. Urbach, D. T. Knauss and E. R. Quandt, Advanced concepts in chemical propulsion for a 500-ton submersible, *Nav. Engng J.* **93**(1), 63–75 (1981).
15. L. H. Back, Laminar boundary-layer heat transfer from a partially ionized monatomic gas, *Physics Fluids* **10**, 807–819 (1967).
16. L. H. Back, P. F. Massier and E. J. Roschke, Partially ionized gas flow and heat transfer in the separation, reattachment and redevelopment regions downstream of an abrupt circular channel expansion, *J. Heat Transfer* **94**, 119–127 (1972).
17. P. E. Pickett, Heat and momentum transfer to internal, turbulent flow of helium–argon mixtures in circular tubes, MSE Report, Aero. Mech. Engng Dept., Univ. Arizona (1976). Available from NTIS as AD-A167 290.
18. A. W. Serksnis, Turbulent flow of hydrogen–carbon dioxide mixtures in heated tubes, MSE Report, Aero. Mech. Engng Dept., Univ. Arizona (1977). Available from NTIS as AD-A062 442/96A.
19. J. C. Hilsenrath, W. Beckett, W. S. Benedict, L. Fano, H. J. Hoge, J. F. Masi, R. L. Nuttall, Y. S. Touloukian and H. W. Wooley, *Tables of Thermal Properties of Gases*. NBS Circular 564 (1955).
20. W. C. Reynolds, *Thermodynamics*. 2nd Edn, p. 228. McGraw-Hill, New York (1968).
21. W. C. Reynolds and H. C. Perkins, *Engineering Thermodynamics*. McGraw-Hill, New York (1968).
22. J. O. Hirschfelder, C. F. Curtiss and R. B. Bird, *Molecular Theory of Gases and Liquids*. Wiley, New York (1964).
23. A. G. Clarke and E. B. Smith, Low-temperature viscosities of argon, krypton, and xenon, *J. Chem. Phys.* **48**, 3988–3991 (1968).
24. R. A. Dawe and E. B. Smith, Viscosities of the inert gases at high temperature, *J. Chem. Phys.* **52**, 693–703 (1970).
25. A. S. Kalelkar and J. Kestin, Viscosity of He–Ar and He–Kr binary gaseous mixtures in the temperature range 25–720°C, *J. Chem. Phys.* **52**, 4248–4261 (1970).
26. V. K. Saxena and S. C. Saxena, Measurements of the thermal conductivity of helium using a hot-wire type of thermal diffusion column, *Br. J. Appl. Phys. (J. Phys. D.)* **1**, 1341–1351 (1968).
27. R. DiPippo and J. Kestin, The viscosity of seven gases up to 500°C and its statistical interpretation, Fourth Symposium on Thermal Physical Properties, New York, pp. 304–313 (1968).
28. Y. S. Touloukian and C. Y. Ho, *Thermophysical Properties of Matter*. Plenum Press, London (1970).
29. J. Kestin, S. T. Ro and W. A. Wakeham, Viscosity of the noble gases in the temperature range 25–700°C, *J. Chem. Phys.* **56**, 4119–4124 (1972).
30. V. K. Saxena and S. C. Saxena, Thermal conductivity of krypton and xenon in the temperature range 350–1500 K, *J. Chem. Phys.* **51**, 3361–3368 (1969).
31. M. Trautz and R. Heberling, Viscosity, thermal conductivity and diffusion in gas mixtures, XXV Internal viscosity of xenon and its mixtures with hydrogen and helium, *Annln Phys.* **20**, 118–120 (1934).
32. E. Thornton, Viscosity and thermal conductivity of binary gas mixtures xenon–krypton, xenon–argon, xenon–neon and xenon–helium, *Proc. Phys. Soc.* **76**, 104–112 (1960).
33. J. M. Gandhi and S. C. Saxena, Correlated thermal conductivity data of rare gases and their binary mixtures at ordinary pressures, *J. Chem. Engng* **13**, 357–361 (1968).
34. E. A. Mason and H. von Ubish, Thermal conductivity of rare mixtures, *Physics Fluids* **3**, 355–361 (1960).
35. P. E. Pickett, M. F. Taylor and D. M. McEligot, Heated turbulent flow of helium–argon mixtures in tubes, *Int. J. Heat Mass Transfer* **22**, 705–719 (1979).
36. M. F. Taylor, K. E. Bauer and D. M. McEligot, Internal convective heat transfer to low-Prandtl-number gas mixtures. Interim technical report, ONR Contract N00014-75-C-0694, Aero. Mech. Engng Dept., Univ. Arizona (1984). Available from NTIS as AD-A148 932/7.
37. A. L. Lindsay and L. A. Bromley, Thermal conductivity of gas mixtures, *Ind. Engng Chem.* **42**, 1508–1511 (1950).
38. A. K. Barua, Thermal conductivity and Eucken-type factor for the binary mixtures H–He, H–Ne, H–Kr and H–Xe, *Indian J. Phys.* **34**, 169–183 (1960).
39. S. C. Saxena and P. K. Tondon, Experimental data and procedures for predicting thermal conductivity of binary mixtures of nonpolar gases, *J. Chem. Engng Data* **16**, 212–220 (1971).

40. J. Kestin, Personal communication, Brown University, Providence, Rhode Island, 3 March (1983).
41. A. A. Clifford, R. D. Fleeter, J. Kestin and W. A. Wakeham, Thermal conductivity of mixtures of hydrogen and helium at 27.5°C and pressures up to 14 MPa, *Ber. Bunsen-Gesellschaft Phys. Chem.* **84**, 18–23 (1980).
42. J. S. Park, M. F. Taylor and D. M. McEligot, Heat transfer to pulsating, turbulent gas flow, *Proc. Seventh Int. Heat Transfer Conf.* **3**, 105–110 (1982).
43. W. K. Moen, Surface temperature measurements, *Inst. Control Syst.* **33**, 70–73 (1960).
44. W. G. Hess, Thermocouple conduction error with radiation heat loss, M.S.E. Thesis, Aero. Mech. Engng Dept., Univ. Arizona (1965).
45. F. Kreith, *Principles of Heat Transfer*, 3rd Edn. Intertext, Scranton (1973).
46. S. J. Kline and F. A. McClintock, The description of uncertainties in single sample experiments, *Mech. Engng* **75**(1), 3–8 (1953).
47. J. A. Malina and E. M. Sparrow, Variable-property, constant-property, and entrance-region heat transfer results for turbulent flow of water and oil in a circular tube, *Chem. Engng Sci.* **19**, 953–961 (1964).
48. D. M. McEligot, S. B. Smith and C. A. Bankston, Quasi-developed pipe flow with heat transfer, *J. Heat Transfer* **92**, 641–650 (1970).
49. T. B. Drew, E. C. Koo and W. H. McAdams, The friction factor in clean, round pipe, *Trans. A.I.Ch.E.* **28**, 56–72 (1932).
50. M. F. Taylor, A method of correlating local and average friction coefficients for both laminar and turbulent flow of gases through a smooth tube with surface-to-fluid-bulk temperature ratios from 0.35 to 7.35, *Int. J. Heat Mass Transfer* **10**, 1123–1128 (1967).
51. M. F. Taylor, Correlation of local heat transfer coefficients for single-phase turbulent flow of hydrogen in tubes with temperature ratios to 23, NASA TN D-4332 (1968).
52. D. M. McEligot, P. M. Magee and G. Leppert, Effect of large temperature gradients on convective heat transfer: the downstream region, *J. Heat Transfer* **87**, 67–76 (1965).

CONVECTION FORCEE INTERNE POUR DES MELANGES DE GAZ A FAIBLE NOMBRE DE PRANDTL

Résumé—Des mélanges binaires de gaz avec des nombres de Prandtl entre 0,18 et 0,7 sont utilisés pour vérifier des formules proposées pour l'écoulement turbulent établi d'un fluide à propriétés constantes dans un tube circulaire. Les relations de Petukhov et Popov et de Kays se comportent bien, tandis que l'analogie classique de Colburn et la formule de Dittus-Boelter surestime notablement le nombre de Nusselt aux faibles nombres de Prandtl. On examine aussi les effets de la variation modérée des propriétés sur le coefficient de frottement et le nombre de Nusselt local.

INTERNE ERZWUNGENE KONVEKTION BEI GASGEMISCHEN MIT NIEDRIGER PRANDTL-ZAHL

Zusammenfassung—Binäre Gasgemische mit Prandtl-Zahlen im Bereich von 0,18 bis 0,7 wurden verwendet, um Korrelationen zu überprüfen, die für die turbulente, voll ausgebildete Strömung eines Fluids mit konstanten Eigenschaften in einem kreisförmigen Rohr vorgeschlagen wurden. Die Beziehungen von Petukhov und Popov und von Kays schnitten am besten ab, während die gängige Analogie von Colburn und die Korrelation von Dittus-Boelter die Nusselt-Zahl bei niedrigen Prandtl-Zahlen zu hoch vorher sagten. Die Auswirkung von Änderungen der Stoffeigenschaften auf die mittleren Reibungsfaktoren und die lokalen Nusselt-Zahlen wurden ebenfalls untersucht.

ВНУТРЕННЯЯ ВЫНУЖДЕННАЯ КОНВЕКЦИЯ В ГАЗОВЫХ СМЕСЯХ С МАЛЫМИ ЧИСЛАМИ ПРАНДТЛЯ

Аннотация—Бинарные газовые смеси, характеризующиеся числами Прандтля от 0,18 до 0,7, использовались для проверки обобщенных соотношений, предложенных для расчета турбулентного полностью развитого течения в круглой трубе жидкости с постоянными свойствами. Оказалось, что соотношения Петухова-Попова и Кейса дают хорошие результаты, в то время как хорошо известная аналогия Колберна и соотношение Диттуса-Болтера существенно завышают значение числа Нуссельта при малых числах Прандтля. Также исследовалось влияние изменения свойств жидкости на суммарные осредненные коэффициенты трения и локальные числа Нуссельта.